

The S-Class Cabriolet. Unleash your senses.



Mercedes-Benz



335 kW or 455 hp. Enough power
to stop the world for a moment.



*Please read the disclaimer.



More speed, less haste.

You remain serene and quietly confident, despite the fact that the S 500 can drive like a sports car. Accompanied by a V8 sound that will hold you enthralled. You will float on AIRMATIC air suspension with an adaptive damping system. You simply cannot get a more advanced, more emotional drive.

*Please read the disclaimer.



*Please read the disclaimer.

Engine and Transmission

Inseparable

V8 Petrol

Eight cylinders – no other engine gets under the skin in quite the same way. As the latest model to follow in this tradition, the S 500 Cabriolet rolls out an unmistakable, irresistible carpet of sound. A specially developed sound control system ensures that this effect comes into play as soon as the car starts or is accelerated sharply, while during normal driving the engine remains completely restrained. In acoustic terms, it thus melds the emotional appeal of a sports car with the comfort of an S-Cabriolet to unique effect.



9G-TRONIC Automatic Transmission

The S-Class Cabriolet is equipped with the 9-speed automatic transmission 9GTRONIC. Featuring nine forward gears, this automatic transmission takes efficiency, comfort and dynamics to a completely new level. The wider gear spread allows a reduction in engine speed. Performance remains excellent, while ride comfort is enhanced and noise levels are reduced. Smaller gear ratio increments and faster gear changes lead to even greater responsiveness and agility, while the car's exceptional efficiency has resulted in even lower fuel consumption. The gentle and almost imperceptible changes of gear made by the transmission are similarly impressive. As 9G-TRONIC is able to skip individual gears, multiple downshifts are possible for fast and powerful sprints.

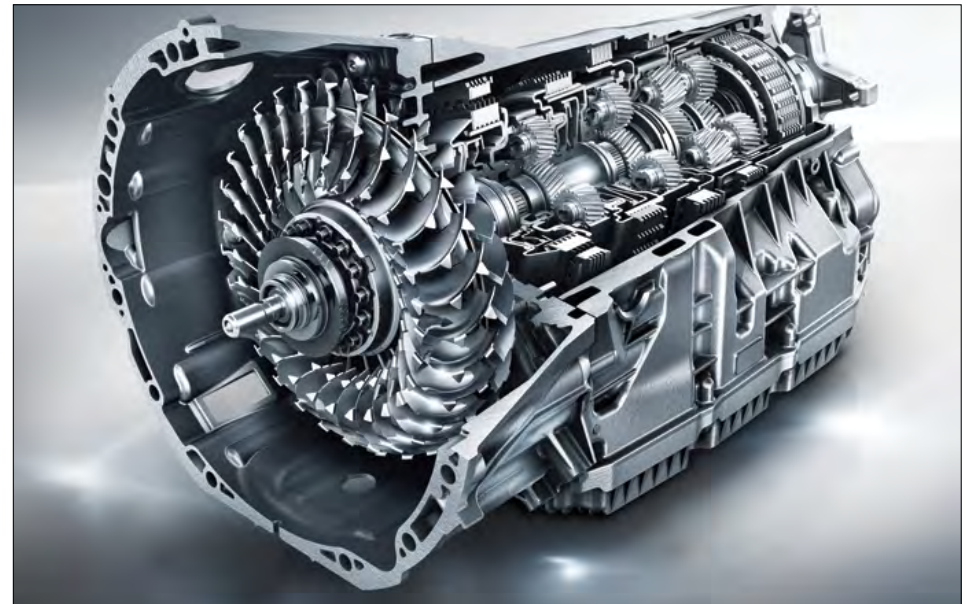

AIRMATIC with continuously variable damping control

More ride comfort, more vehicle dynamics

In combination with variable damper control, the air suspension system ensures ride comfort and dynamic handling at a very high level. The damping at each wheel is adapted to the current driving situation and road surface condition. This is done rapidly and precisely using two separate valves for the compression and rebound of the dampers. The occupants enjoy a soft basic suspension setup and the secure feeling of high handling stability as speed increases. Hardening of the spring rate, for example on bends and when braking, effectively reduces rolling and pitching movements. With the “Comfort” and “Sport” settings, AIRMATIC can be configured for more comfort or sportiness. Thanks to the pneumatic all-round selflevelling suspension, the vehicle maintains a constant level irrespective of the load. The suspension level can be raised by 30 mm to increase ground clearance. At high speeds the suspension is automatically lowered by up to 20 mm, helping to reduce aerodynamic drag and improve handling stability.

Features of AIRMATIC with variable damper control:

- Air suspension struts at the front and rear axle
- Dampers with two separate valves for the compression and rebound phases
- An electronically controlled air pump
- A central reservoir system for 4x4, valve unit with central pressure sensor
- Air suspension valves
- An electronic control unit
- Sensors for damper and level control: 3 body acceleration and 4 level sensors
- Operating keys with control lamps



Standard options

Soft top operation – convenient and automatic

The soft top of the S-Class Cabriolet is made out of an extremely hard-wearing and attractive quality fabric and is available in the colours black, blue, beige and dark red. It also features exceptional noise insulation. The acoustics have been honed down to the minutest detail: a horizontal seam above the rear window joins the sections of fabric together. The Cabriolet is still best driven open: which is why you can open the roof even when driving at speeds of up to 50 km/h. Retraction time of only 17 seconds makes it one of the fastest retracting convertibles in the world.



AIRCAP – protection against draughts

In a class of its own in terms of climate and noise comfort, too: even in low temperatures or stormy conditions, the S-Class Cabriolet makes open-top driving an enjoyable affair. The draught stop system significantly reduces air turbulence in the interior. Activating the AIRCAP switch causes a wind deflector above the windscreen to extend, together with a draught stop behind the head restraints.



AIR-BALANCE package - In the Mood

The interior of the vehicle can be given a subtle and individual fragrance with the help of the optional AIR-BALANCE package. This consists of a fragrance generator located in the glove compartment, a glass flacon and an atomiser head. Four high quality fragrances are available: NIGHTLIFE MOOD, DOWNTOWN MOOD, SPORTS MOOD, FREESIDE MOOD – plus an additional PACIFIC MOOD fragrance developed specifically for the S-Class Cabriolet. A further flacon can be filled with a personal choice of fragrance. The intensity and duration of perfume atomisation are adjustable. The fragrance is always subtle, unobtrusive and fades away rapidly once the system is switched off.



Standard options

Burmester® high-end surround sound system - Music to the eyes

The sound is almost beyond words. A total of 23 loudspeakers with an output of 1520 watts transform the interior into an acoustic dream. The bass speaker alone has an output of more than 400 watts. However, the Burmester® High-End 3D surround sound system is just as amazing when it's switched off. The speakers are designed like miniature works of art and feature an exceptionally high-quality finish.



Head-up display - keeping an eye on the road ahead

Key driver information at a glance, without the driver having to take their eyes off the road – this is a feature made possible by the Head-up display. It projects a virtual image measuring approximately 21 x 7 cm into the driver's field of vision, which appears to float around 2 metres in front of him/ her, above the bonnet. The information is displayed in high-resolution and in colour. The height of the display can be adjusted, making it easy to read for drivers of all sizes.



360° camera – for an all-round parking view

This system makes parking and manoeuvring with a realistic all-round view possible with the help of four networked cameras. The vehicle and its immediate surroundings can be shown as a bird's-eye view on the COMAND Online display. Obstacles below the window line are also visible to the driver. The 360° camera can be activated by engaging reverse gear, by pressing a button or via the COMAND Online menu.





designo Customisation Options - Additional features

Luxury Option 1

LED Intelligent Light System with Swarovski crystals + Night View Assist Plus - A new and exceptional day and night design is created by the inclusion of fine Swarovski crystals in the headlamps. Their fascinating play of light in the indicators and daytime running lamps provides striking visual highlights and emphasises the unique nature of the vehicle. This feature comes clubbed with Night View Assist Plus safety feature.



Luxury Option 2

Night View Assist Plus - Only 20% of road traffic is at night-time, but 40% of all fatal accidents occur during this period. This system enables drivers to detect pedestrians or larger animals sooner in the dark. They are clearly highlighted in the cockpit display. The spotlight function enables endangered pedestrians to be flashed at several times, so that the driver registers them even more quickly and the former recognise the danger. As standard the night view image only appears automatically when a hazardous situation is recognised.



Comfort Option 1

Seat Comfort package - Thanks to their inflatable air chambers, the active multicontour seats with ENERGIZING massage function and dynamic function ensure the best possible seating comfort and outstanding lateral support. The massage programmes enhance well-being, also using heat according to the principle of a relaxing hot-stone massage. The ENERGIZING massage function stimulates and relaxes the back muscles as required, with 14 air chambers, six programs and two intensities.

Comfort Option 2

Climatised front seats - The active ventilation function of the climate-controlled seats rapidly cools the seat surfaces to a pleasant temperature to ensure well-balanced seating comfort. In cold weather conditions, the on-demand seat heating provides cosy warmth as required. Seat ventilation and seat heating can be independently set in three stages at the touch of a button.

designo Customisation Options - Upholstery and trim

UPHOLSTERY

Black / black

Porcelain / espresso brown

Saddle brown / black

Porcelain / deep-sea blue

Bengal red / black

Crystal grey / black

TRIM

High-gloss burr walnut wood trim in brown

Black high-gloss poplar wood trim

designo metallised ash wood

AMG carbon-fibre/black piano lacquer trim

black *designo* piano lacquer

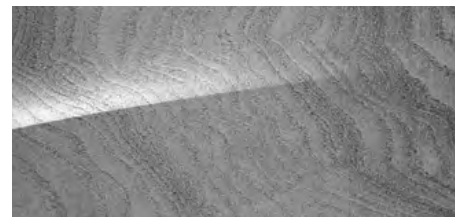
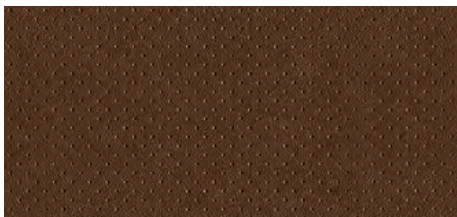
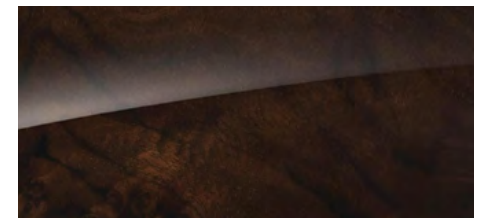
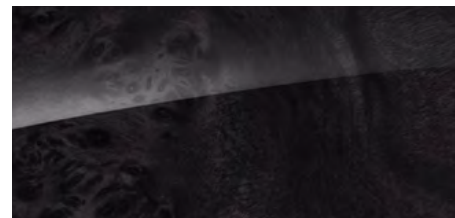
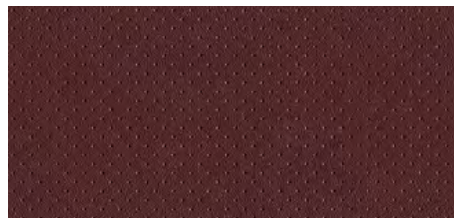
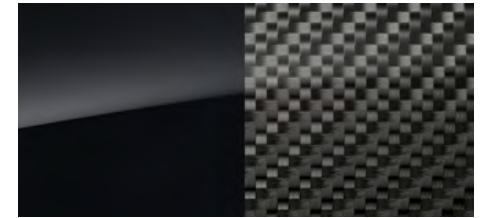

designo Customisation Options - Paintwork and Alloy

PAINTWORK

992U selenite grey metallic

890U cavansite blue metallic

998U Anthracite blue metallic

183U magnetite black metallic

897U ruby black metallic

799U designo diamond white bright

775U iridium silver metallic

989U Emerald green metallic

033U designo mocha black metallic

ALLOY

48.3 cm (19") 5 twin spoke light alloy wheels

48.3 cm (19") multi spoke light alloy wheels

48.3 cm (19") multi spoke light alloy wheels

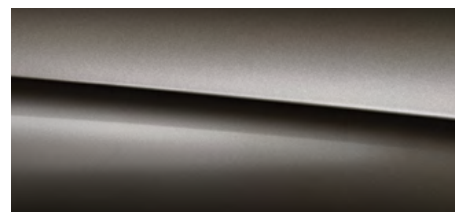
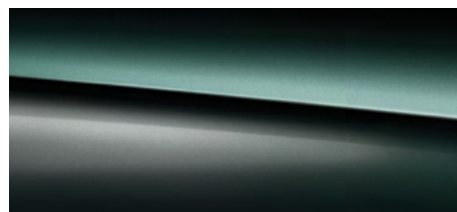
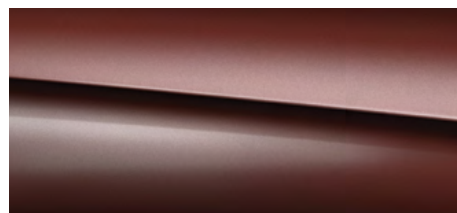
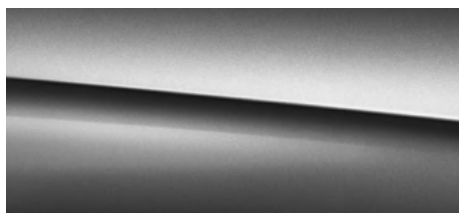
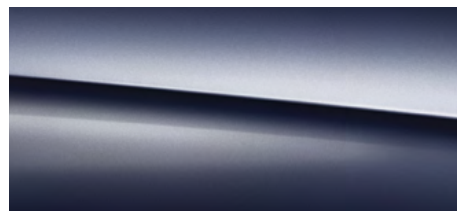
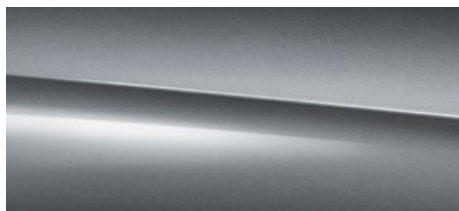

*Please read the disclaimer.

designo Customisation Options - Design your roof

ROOF TOP

Fabric soft top black

Fabric soft top blue

Fabric soft top beige

Fabric soft top dark red



Dimensions

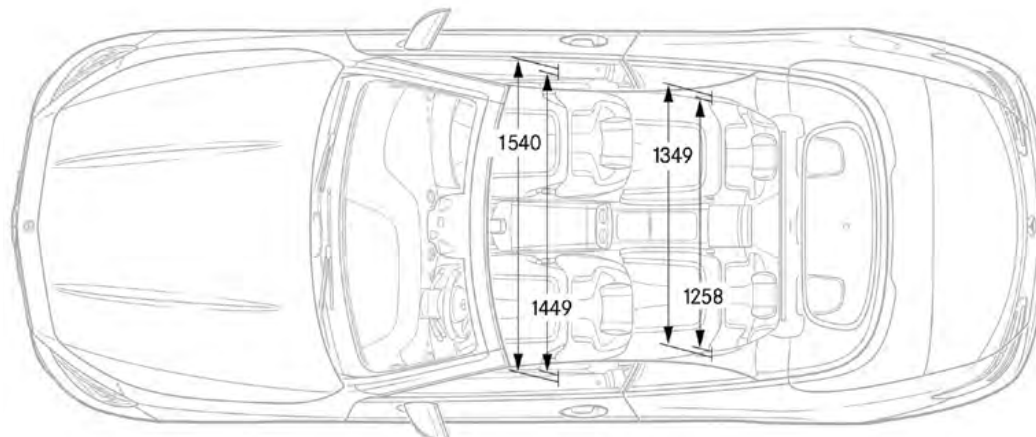
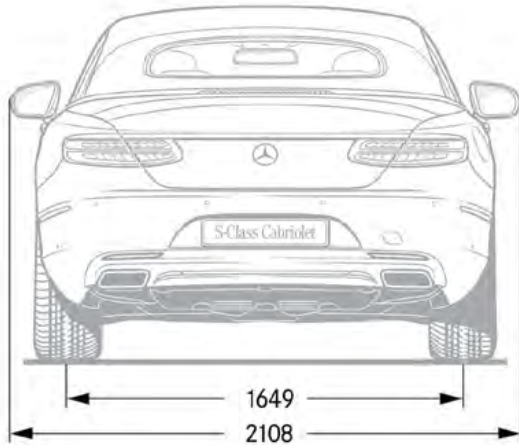
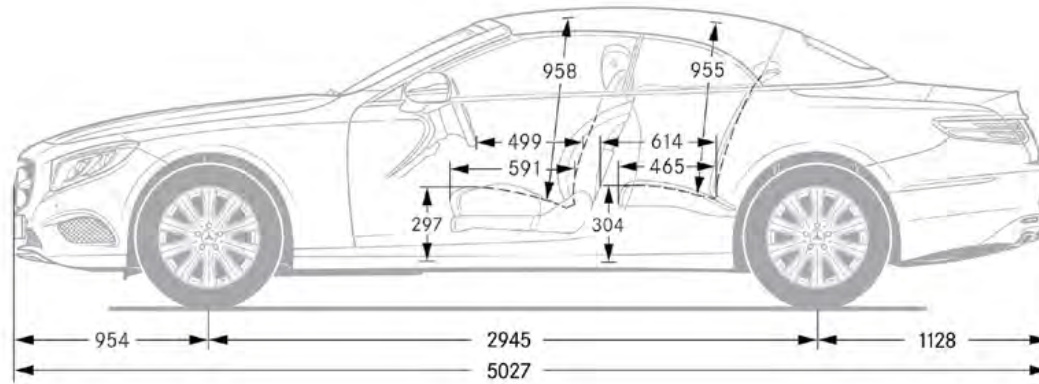
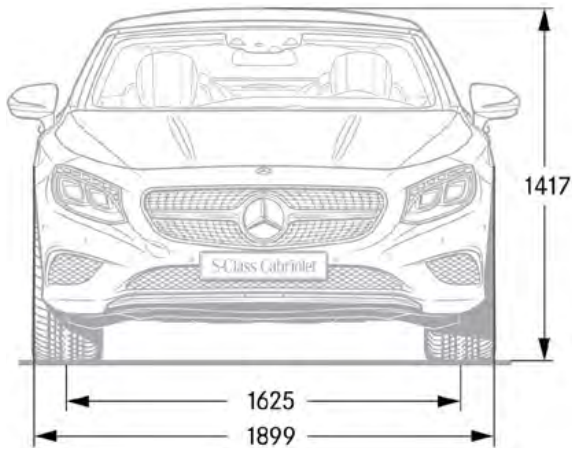

All dimensions in millimetres. The dimensions shown are mean values and apply to standard-specification, unladen vehicles. The dimensions shown correspond to vehicles with a petrol engine.

*Please read the disclaimer.

Technical data.

	S 500 Cabriolet
No. of cylinders/arrangement	V8
Total displacement in cc	4663
Rated output in kW (hp) at rpm	335 (455) @ 5250-5500
Rated torque in Nm at rpm	700/1800-3500
Transmission	9G-TRONIC
Acceleration from 0 to 100 km/h in s	4.6 seconds
Top speed, approx. in km/h	250 km/h
Tank capacity, of which reserve, approx. in l	80/8.0
Turning circle diameter in m	11.6
Kerb weight in kg	2115
Perm. GVW in kg	2590
Wheelbase in mm	2945
Length x Width x Height (mm)	5027 x 1899 x 1417

Service

The luxurious experience of driving a Mercedes-Benz is converted into a fulfilling ownership experience with a range of exclusive services and special programmes.

Cost of Ownership

There has been a paradigm shift in the buying preferences of Indian consumers over the years, even for the luxury products. The purchase decision not only dwells around cost of acquisition but also the total 'Cost of Ownership' (COO). Amongst the key components of COO in cars are the routine service jobs and the unplanned repair expenses post the warranty period. We are now offering highly-affordable Service Packages and Extended Warranty Programmes which are the most competitive packages in its class. All in all, we provide you with a controlled Cost of Ownership while you benefit from the legendary Mercedes-Benz service quality.

Experience complete peace of mind when you drive the Star

STAR CARE programme offers peace of mind drive for you during warranty period and beyond. While our cars are covered for warrantable repairs up to 3 years without any mileage limitations, as standard, you can also buy STAR CARE Plus programme, offering 4th year extended warranty. Additionally, the programme enhances the resale value of your car.

STAR EASE Service Package gives you the freedom to relax behind the wheel and puts your mind at ease with its range of unique benefits such as defined cost of maintenance and priority handling. STAR EASE Comprehensive package covers essential jobs related to periodic service (viz. oil, filters, consumables, etc.) along with coverage for brake pads, brake discs, wiper blades and wheel alignment & balancing, for a contracted period. For further details on products and pricing, please contact your nearest Mercedes-Benz dealer.

On-Road Assistance Programme

As part of our ongoing commitment to you, Mercedes-Benz On-Road Assistance is designed to enhance your overall Mercedes-Benz ownership experience by providing you with 24-hour On-Road Assistance. Mercedes-Benz is the only Luxury car manufacturer to offer round-the-clock On-Road Assistance for 3 years from purchase of vehicle as a standard offering. Peace of mind motoring – guaranteed.



Extended Warranty that guarantees complete peace of mind



The maintenance of your Star is just as peaceful as driving it



Always at your service

India's Largest Luxury Car Network

It takes a keen sense of responsibility to provide the Best. Our large network is spread across the country in 40 cities with 86 outlets and is still growing. With world-class showrooms, state-of-the-art workshops and highly skilled personnel, experience the best wherever you go.



DEALER CONTACT:

NORTH & EAST:

BHUBANESWAR:
Tristar Motors: 0-7852944100

CHANDIGARH:
Joshi Autozone: 0172-5050500
Panjab Motors: 0172-4290000

DEHRADUN:
Berkeley Motors: 0135-3054000

DELHI:
T & T Motors, Mohan Co-operative,
Mathura Road: 011-66574300/330
Rajouri Garden: 011-66574400/430

GHAZIABAD:
Silver Arrows: 0-9718200500

GURGAON:
T & T Motors: 0124-4263060/62

JAIPUR:
T & T Motors: 0141-4300000/05

JAMSHEDPUR:
Tristar Motors: 0-7763815720/
0657-6601601/02

JALANDHAR:
Joshi Autozone: 0181-5004444

KANPUR:
Smart Hoops: 0-8795663300

KARNAL:
Berkeley Motors: 0184-3300000

KOLKATA:
Benchmark Interkrafts: 1800 3000 3310

LUCKNOW:
Smart Hoops: 0522-6004008/9

LUDHIANA:
Joshi Autozone: 0161-5055000

MOHALI:
Panjab Motors: 0172-4290000

NOIDA:
Silver Arrows: 0-9999200500

WEST:

AHMEDABAD:
Benchmark Cars: 0-9377662000

EMERALD MOTORS: 0792-6446694/95

AURANGABAD:
B. U. Bhandari: 0-8605121333/
0240-6452601/02

BHOPAL:
Benchmark Cars: 0-9098233233

GOA:
Counto Motors: 0832-2415122

INDORE:
Benchmark Cars: 1800-3000-8844

KOLHAPUR:
B. U. Bhandari: 0231-2661422/
0-8380093555

MUMBAI:
Auto Hangar, Prabhadevi: 022-67434362/63

Auto Hangar, Andheri: 022-67106660/61
Metro Motors, Auto Hangar division
Hughes Road: 022-66123500/11
Shaman Wheels, Off BKC: 022-24228787

NAVI MUMBAI:
Shaman Wheels: 022-24228787

NAGPUR:
Auto Hangar: 0-9223540191/
07104-238180/1/2/3

NASHIK:
Indisch Motoren: 0253-6645555

PUNE:
B. U. Bhandari, Baner: 020-67212129
B. U. Bhandari, Bund Garden: 020-67212131
Trinity Motors: 020-67342525

RAJKOT:
Benchmark Cars: 0-9377750050

RAIPUR:
Auto Hangar: 0771-6537801/0-8518887155

SURAT:
Benchmark Cars: 0-9377660066

VADODARA:
Benchmark Cars: 0-9377390001

SOUTH:

BENGALURU:
Sundaram Motors: 080-22070720/21

Akshaya Motors, Mysore Road:
080-22966300, 0-9066030989

Akshaya Motors, Koramangala:

080-22966296, 0-9019326026

CALICUT:
Bridgeway Motors: 0495-30 55555

CHENNAI:
Trans Car: 044-40200300
Titanium Motors: 044-66498080/8181/8282

COIMBATORE:
Sundaram Motors: 0422-2452020

COCHIN:
Rajasree Motors:
0484-2706332/2706432/2706134
2607027/37/47

HYDERABAD:
Mahavir Motors: 040-43403004
Silver Star: 040-30003535/0-72888862888

MADURAI:
Sundaram Motors: 0452-2320433/
0-9500966946

MANGALORE:
Sundaram Motors: 0824-2214833/2215833/
0-9008442155

TRIVANDRUM:
Rajasree Motors: 0471-2380377/
0-9846547551

VIJAYAWADA:
Mahavir Motors: 0866-2082559/
0-9885303004

MERCEDES-BENZ CERTIFIED:

AHMEDABAD:
Benchmark Cars: 0-9016665000
Emerald Motors: 0792-6446694/95

BENGALURU:
Akshaya Motors: 0-9019944044
Sundaram Motors: 080-22070746/
0-9880662051

CHANDIGARH:
Joshi Autozone: 0-9878941930/
0172-5050500/510

CHENNAI:
Transcar: 0-9841049994

COIMBATORE:
Sundaram Motors: 0422-2452020

DELHI:
T&T Motors, Mathura Road: 0-9711774424
T&T Motors, West Delhi: 0-9711112243

GHAZIABAD:
Silver Arrows: 0-9718200500

HYDERABAD:
Adishwar: 0-7799633004

INDORE:
Benchmark Cars: 0731-6675520

KOCHI:
Rajasree Motors: 0-9846547311

LUCKNOW:
Smart Hoops: 0-8189004408/9/10

MOHALI:
Panjab Motors: 0172-4290000

MUMBAI:
Autohangar India: 0-9223546204,
0-9223547099
Shaman Wheels: 0-9619023450/
022-69543333

PUNE:
B U Bhandari: 020-67212172/0-8605118555

AMG PERFORMANCE CENTERS:

BENGALURU:
Sundaram Motors: 080-22070720/21

DELHI:
T&T Motors: 011-66574309

HYDERABAD:
Mahavir Motors: 0-9885033004/
0-9885653004

MUMBAI:
Auto Hangar: 022-67434360/61/65

PUNE:
B.U. Bhandari: 020-67212131/0-8554055555

Our national toll-free no.:
1800 102 9222

One Call. All Answers.

For a complete list of
Mercedes-Benz outlets,
please explore the dealer locator
tab on www.mercedes-benz.co.in

Mercedes-Benz India Private Limited: E-3, MIDC Chakan - Phase III, Chakan Industrial Area, Kuruli & Nighoje, Tal: Khed, Pune - 410 501 (India)
Toll free No.: 1800 102 9222. e-mail: customerconnect@daimler.com, **website: www.mercedes-benz.co.in**

Please note: This brochure is intended for general information, description and illustration of the Product including optional functions and equipment and may not be specific to a Product since specification of a product may change from time to time. Optional features, functions and equipment etc. may not be present in the Standard or Variant Product or Special Edition Product. Further, Standard specifications of a product may also vary from time to time. Colours may differ from those shown in pictures in the brochure, owing to printing. Mercedes-Benz India reserves the right to make changes, at any point of time, without prior notice, in design, colours, materials, components, equipment, specifications, features, functions, make and models etc. The information given in this brochure shall be regarded as accurate at the time of going to print and may vary thereafter due to any developments or any other reason. Interested parties should confirm with the Authorised Dealer about the correct specification of the product they desire to purchase. For the latest authentic information and updates, kindly contact your nearest Authorised Dealer.

All title, ownership rights and intellectual property rights in and relating to this brochure / magazine or publication material or any copies thereof including but not limited to copyright, logos, names, trademarks, service marks, design, text, images, links, concepts and themes are owned by Daimler AG and/or its subsidiaries collectively or used under authorised license by the Daimler AG. Any reproduction, transmission, publication, performance, broadcast, alteration, license, creation of derivative works or other use in whole or in part in any manner without the prior written consent of the Daimler AG is strictly prohibited.

Month of going to press: October, 2016. Mercedes-Benz cars: The S-Class meets Bharat Stage IV equivalent emission norms.

CIN - U34102PN1994PTC083160